

Solid Figures

Name the faces, edges, and vertices of each polyhedron.

1.

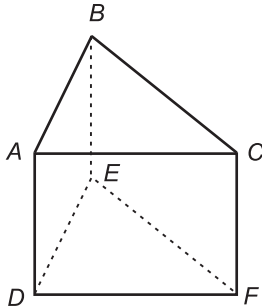

2.

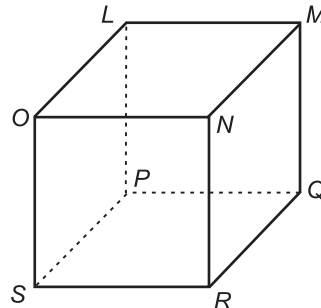

Identify each solid.

3.

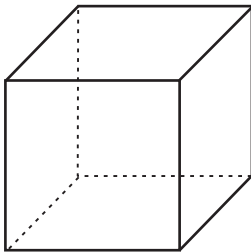

4.

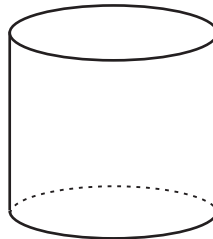

5.

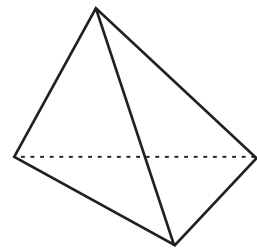

Determine whether each statement is true or false for the solid.

6. The figure is a prism.
7. The figure is a polyhedron.
8. Pentagon $ABCDE$ is a lateral face.
9. The figure has five lateral faces.
10. Pentagon $ABCDE$ is a base.

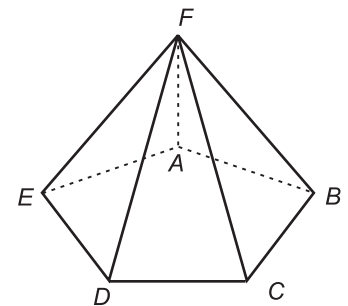

Practice

Surface Areas of Prisms and Cylinders

Find the lateral area and the surface area for each solid.
Round to the nearest tenth, if necessary.

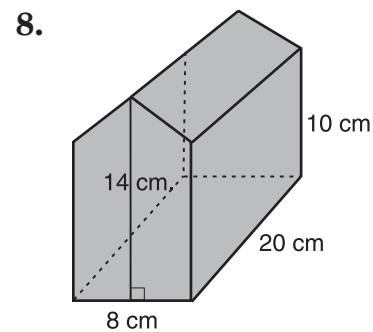
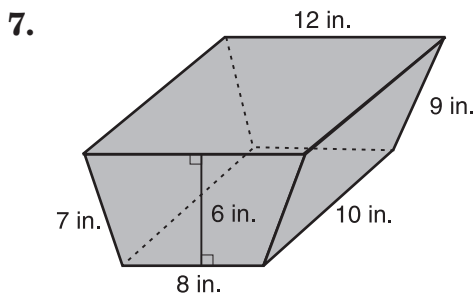
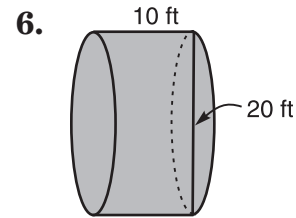
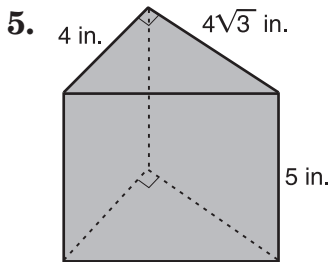
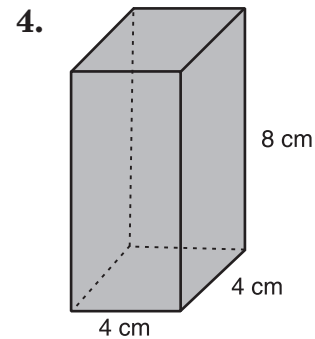
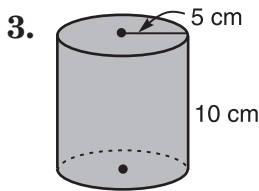
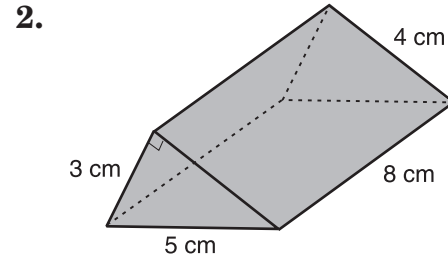
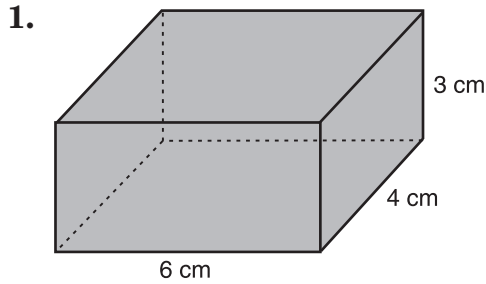

Practice

Volumes of Prisms and Cylinders

Find the volume of each solid. Round to the nearest tenth, if necessary.

1.

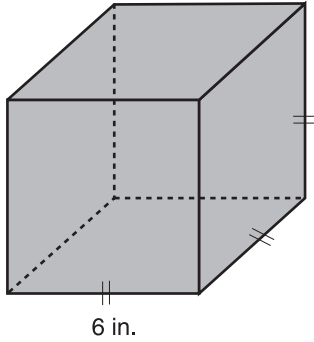

2.

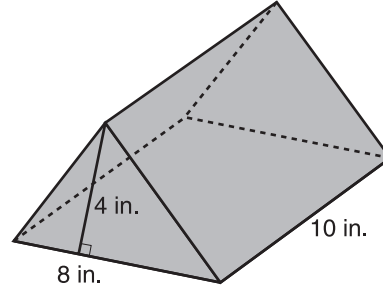

3.

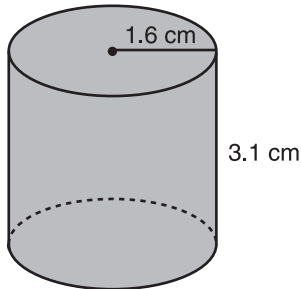

4.

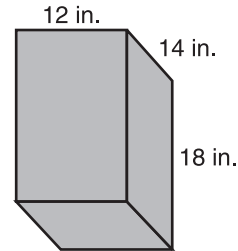

5.

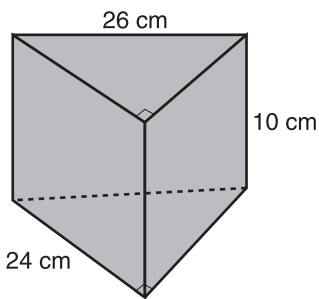

6.

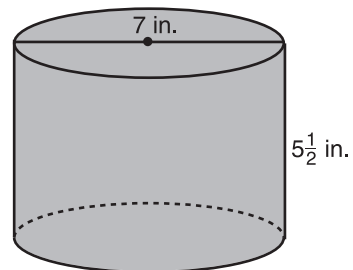

7.

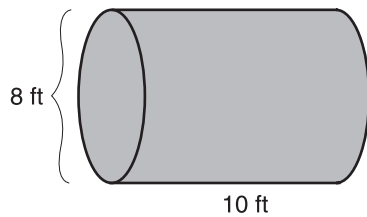

8.

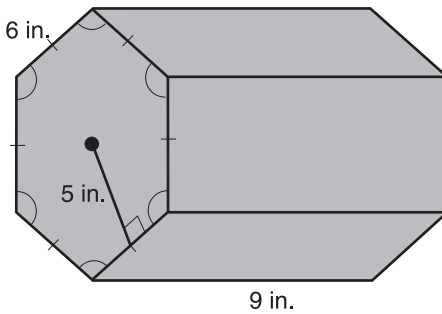

Practice

Surface Areas of Pyramids and Cones

Find the lateral area and the surface area of each regular pyramid or cone. Round to the nearest hundredth.

1.

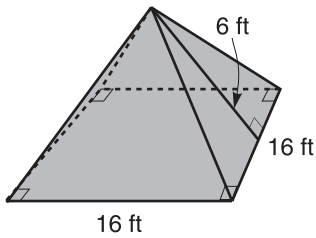

2.

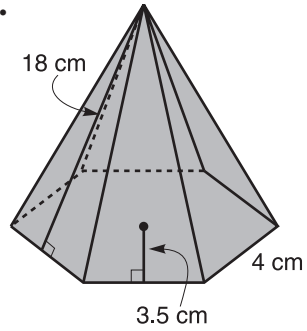

3.

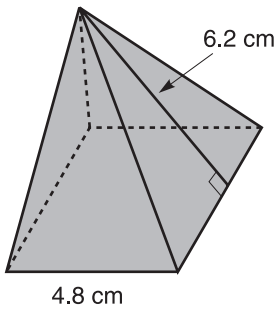

4.

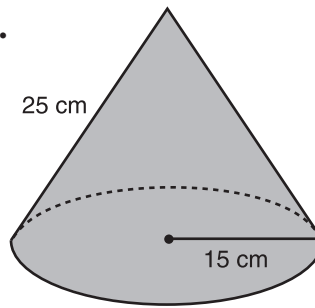

5.

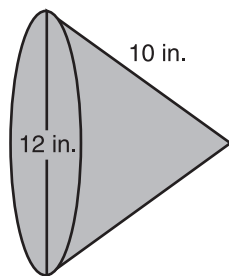

6.

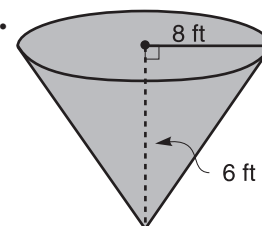

Practice

Volumes of Pyramids and Cones

Find the volume of each solid. Round to the nearest hundredth, if necessary.

1.

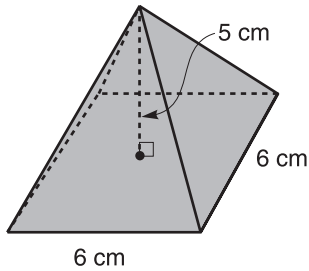

2.

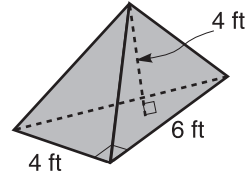

3.

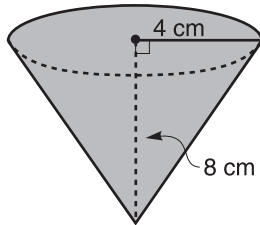

4.

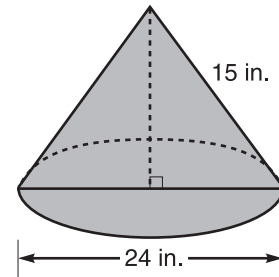

5. A pyramid has a height of 16 centimeters and a base with area of 84 square centimeters. What is its volume?

6. A cone has a height of 12 inches and a base with a radius of 16 centimeters. Find the volume of the cone.

Spheres

Find the surface area and volume of each sphere.
Round to the nearest hundredth.

1.

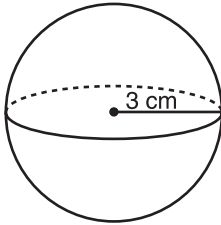

2.

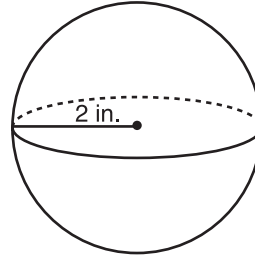

3.

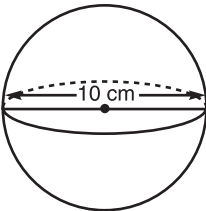

4.

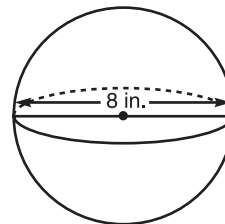

5. Find the surface area of a sphere with a diameter of 100 centimeters. Round to the nearest hundredth.
6. What is the volume of a sphere with a radius of 12 inches?
Round to the nearest hundredth.

Practice

Similarity of Solid Figures

Determine whether each pair of solids is similar.

1.

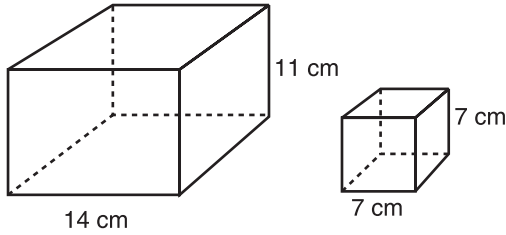

2.

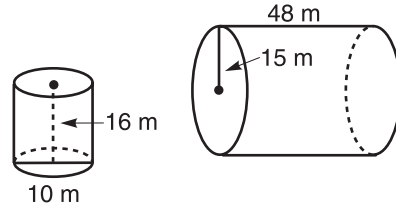

For each pair of similar solids, find the scale factor of the solid on the left to the solid on the right. Then find the ratios of the surface areas and the volumes.

3.

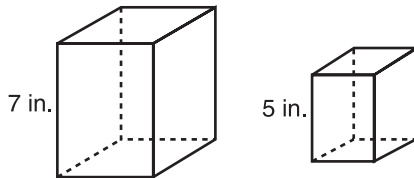

4.

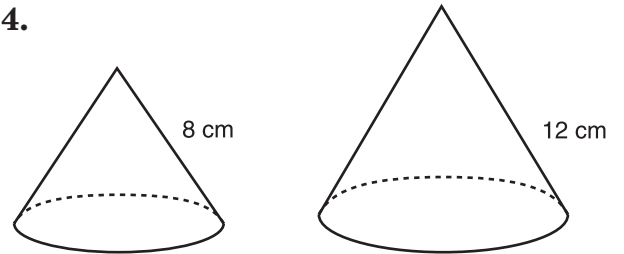

5.

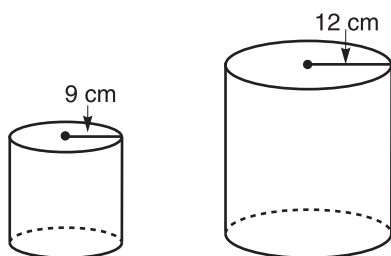

6.

